

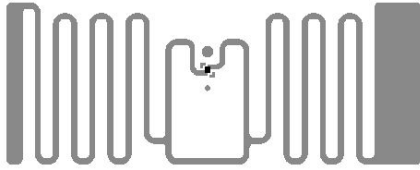

ALN-9720

“HiScan” RETAIL INLAY

The Alien Technology® ALN-9720 “HiScan” RFID inlay is a specialized tag designed for the most challenging retail and apparel applications. The tag is particularly effective with handhelds or other lower-power readers.



Applications

- Retail
- Apparel
- Use with handheld RFID readers

FEATURE	DESCRIPTION	BENEFIT
Tuned for high-performance reading in lower-power reading environments	Designed to return data to the reader even when the reader is providing low power to the tag (such as handheld readers or where tags are behind multiple retail items).	Extremely high read-rates in real-life, every day retail environments (e.g. rapid handheld movement, many tags close to each other etc).
Next generation Higgs™ 4 features and performance	A mass-market optimized tag with class leading read and write performance. Supports pre-encoded MCS serialization and Aliens <i>BlastWrite</i> ™	Rapid programming of serialized tags and excellent read/write performance

Features:

- › Designed to meet EPCglobal Gen2 (V1.2.0) and ISO/IEC 18000-6C
- › Worldwide operation in the RFID UHF bands (840-960 MHz)
- › 448-Bits of NVRAM Memory
 - 128-EPC Bits
 - 128 User Bits
 - 64 Bit Unique TID
 - 32 Bit Access and 32 bit Kill Passwords
- › Pre-Programmed with a unique, unalterable 64-bit serial number
- › User Memory can be Block Perma-Locked as well as read password protected in 32 Bit Blocks
- › Class leading read and write performance
- › Pre-encoded Multivendor Chip Serialization (MCS)
- › *BlastWrite*™ and *QuickWrite*™ mass-encoding
- › Dynamic Authentication™ - anti-cloning/anti-counterfeit technology
- › Available in high-yield, high capacity dry/wet inlay rolls

Product Overview:

Powered by Alien®’s break-through **Higgs™ 4 UHF RFID IC** and **innovative “HS” antenna design**, the ALN-9720 delivers industry leading EPC Gen 2 performance and reliability for retail and apparel applications where handheld readers are used or when tags may be “hidden” behind many similar retail items.

With its Higgs-4 core, the “HiScan” delivers next generation read and write performance, yet is completely **optimized for the highest volume enterprise, retail, and automotive applications.**

An optimized memory footprint includes a 32-bit TID, a **64-bit Unique TID for authentication** and **next generation serialization** applications, a 128-bit EPC memory bank, 128-bits of user memory for distributed data applications, and **password protected read and write** support capabilities to prevent unauthorized viewing and modification of the tag’s data.

ALN-9720 inlays are World Tag compliant, enabling consistent operation across the diverse frequencies of the Americas, Europe, Middle East, Asia, and Africa.



All dimensions in millimeters unless specified otherwise

ALN-9720 Basic Dimensions

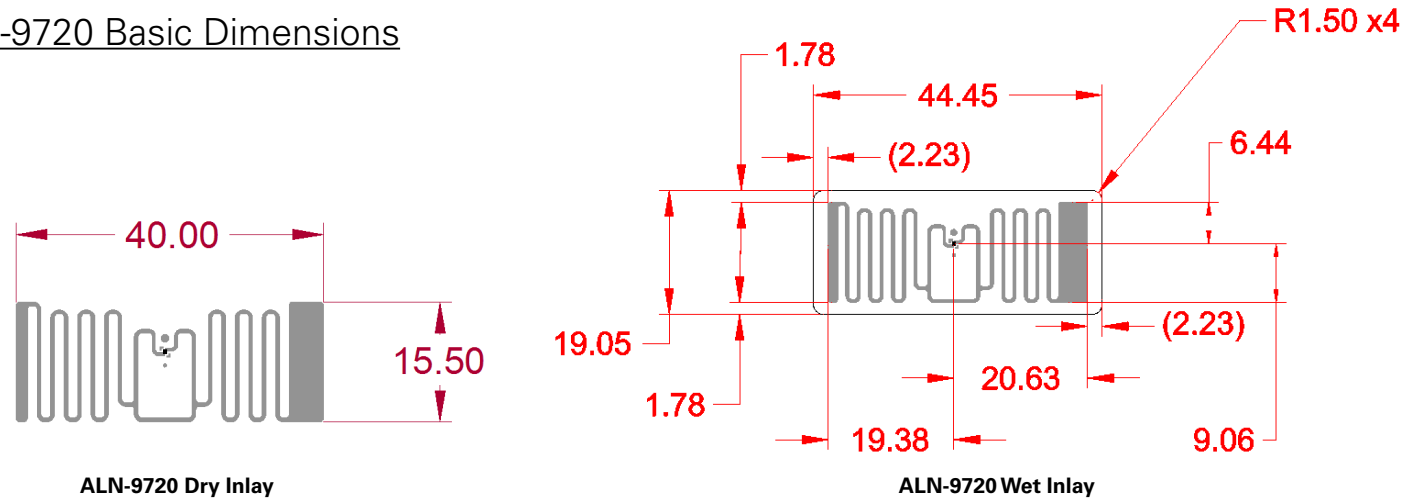

ALN-9720 Inlay Specification

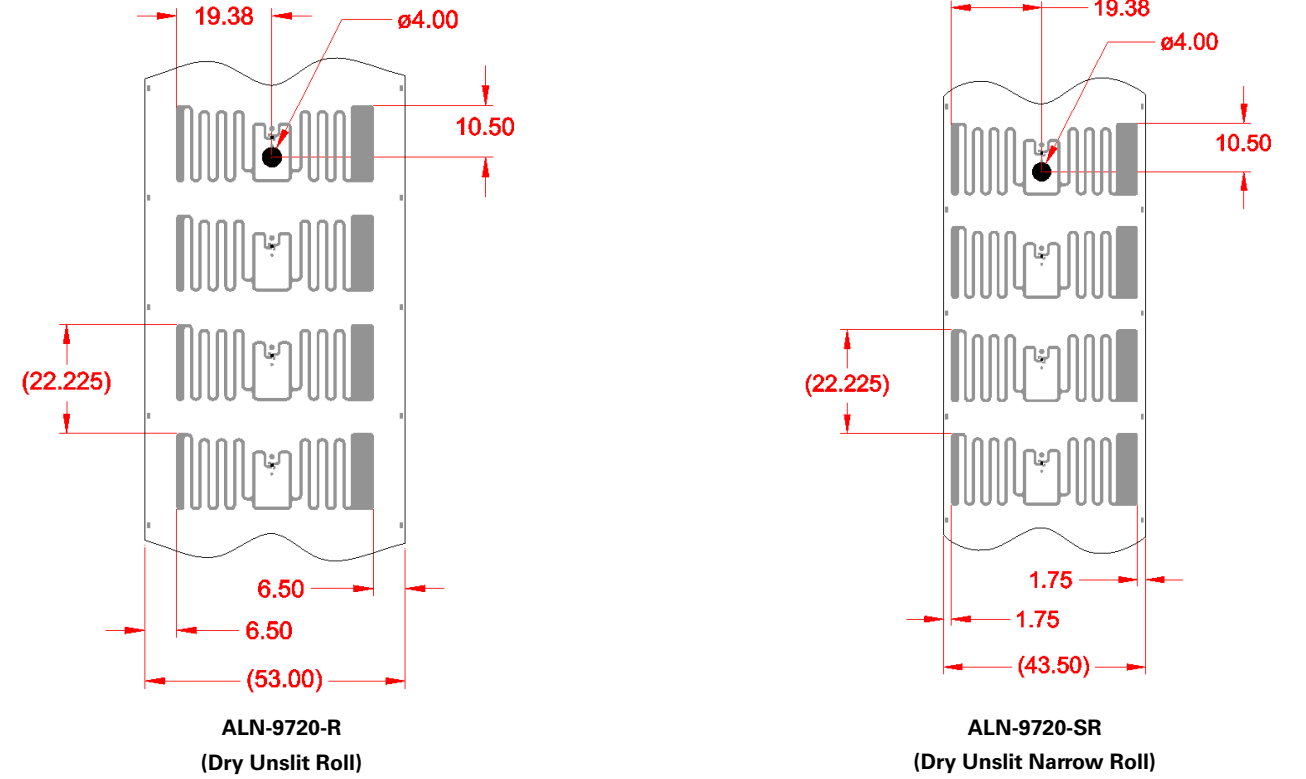

ALN-9720 Inlay Orientation

Standard Alien Inlay rolls unwind with metal antenna side facing outward, with respect to the core.

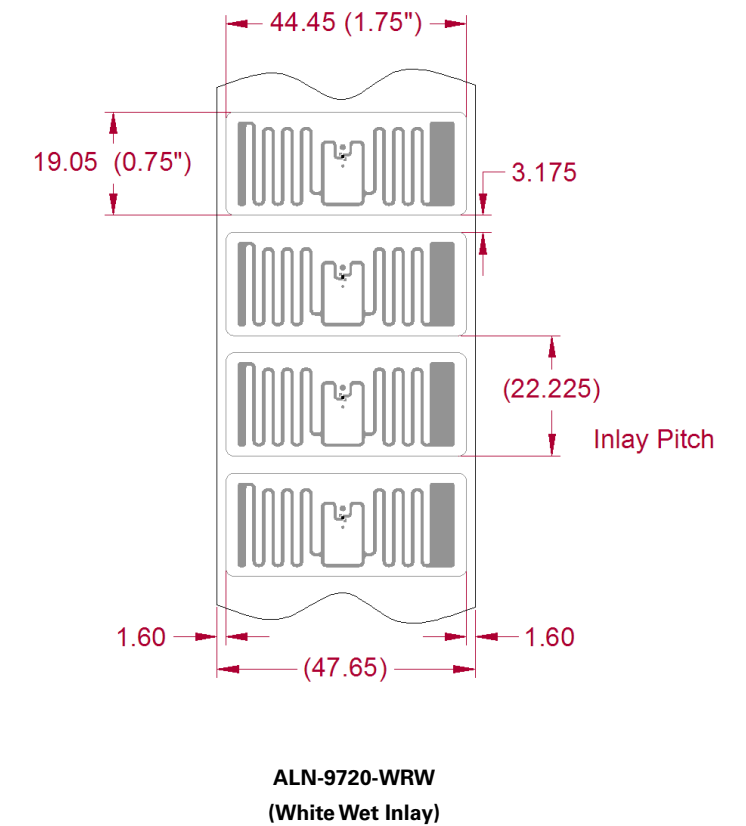
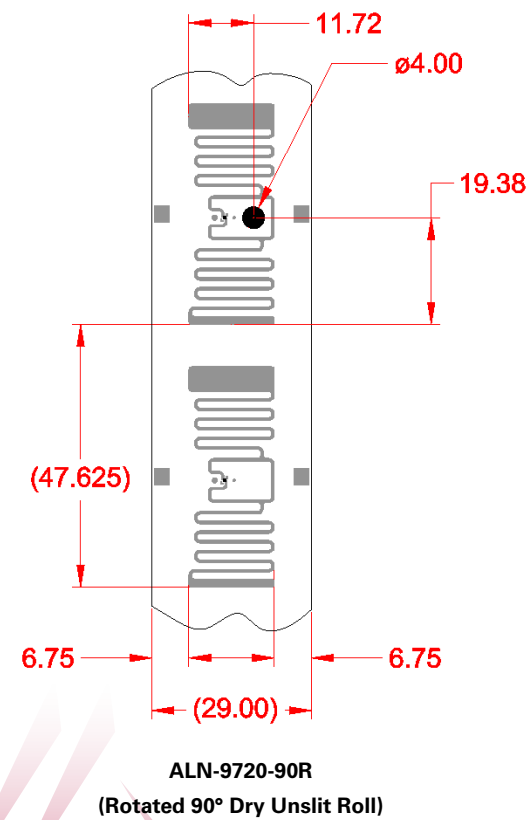
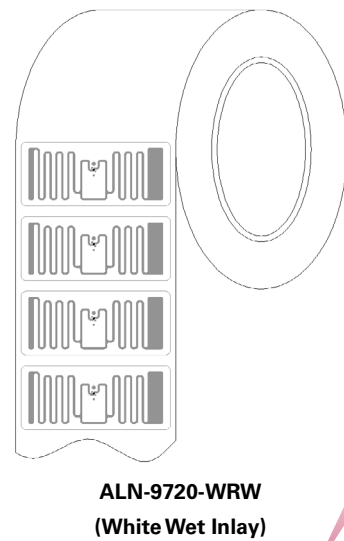
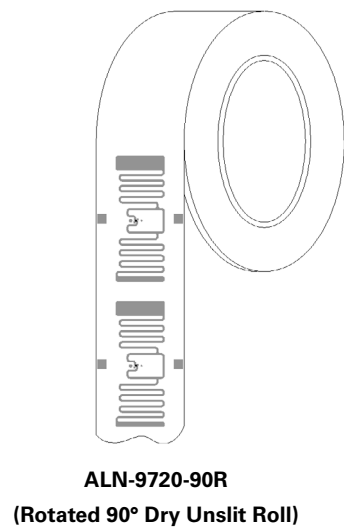
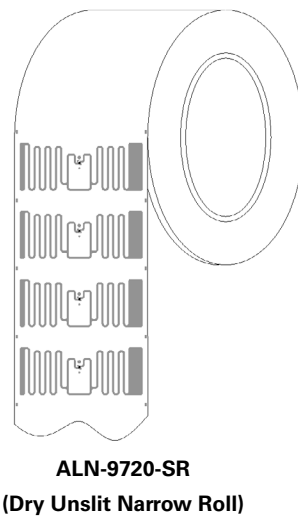
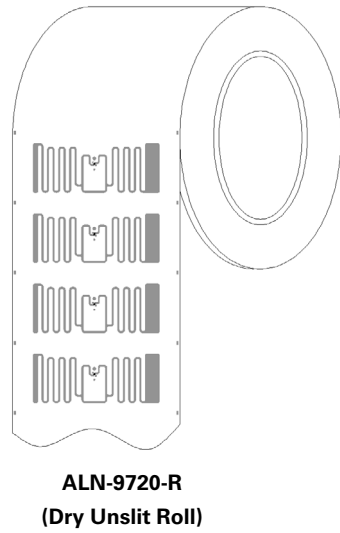

ALN-9720 Inlay Stackup

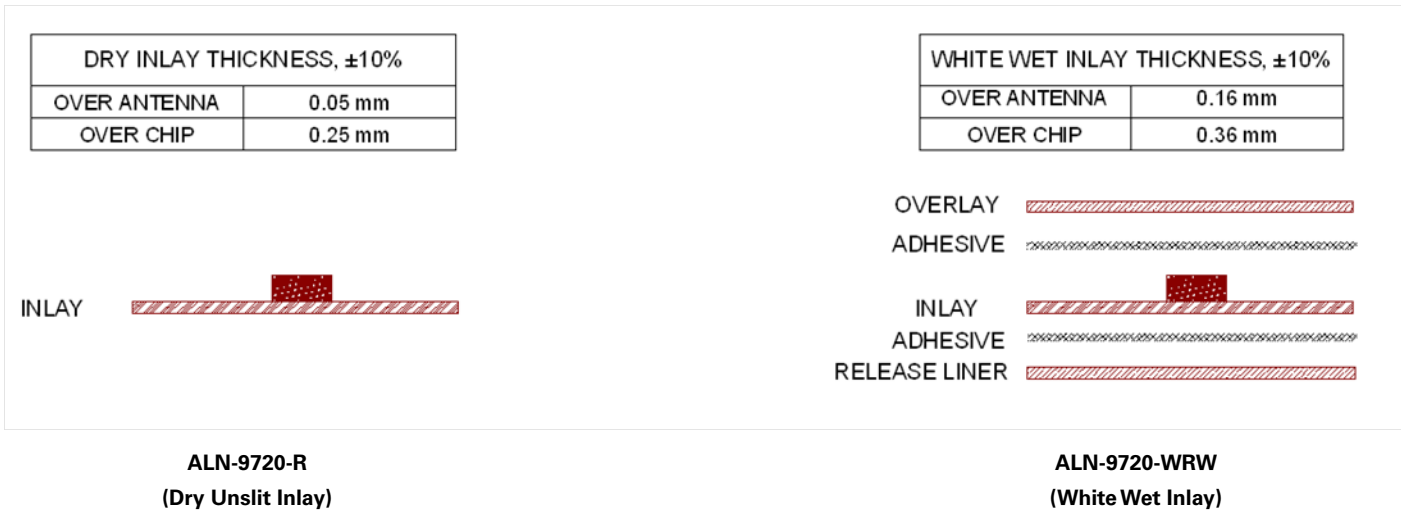

ALN-9720 Inlay Angular Sensitivity

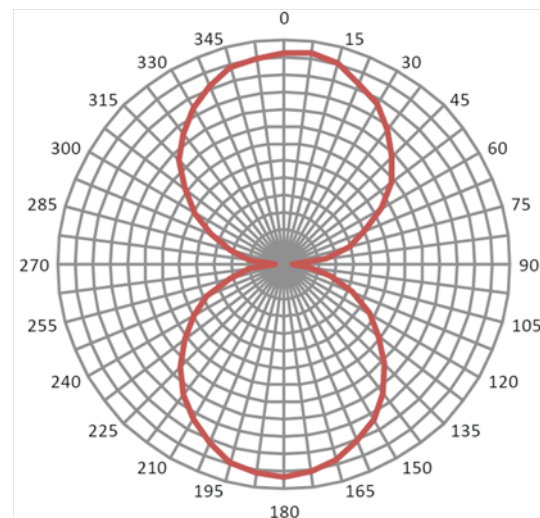

Angular Sensitivity
(Relative Read Range vs. Orientation)

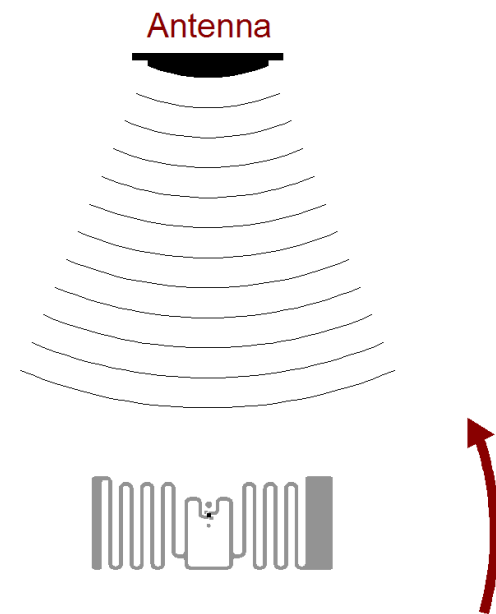

Angular Sensitivity
Inlay is rotated in the x, y, plane about the z axis
(tag shown at 0° with respect to face of antenna)

ALN-9720 Specifications

Dry Inlay	ALN 9720-R	ALN-9720-SR	ALN-9720-90R
Antenna Width	1.57" [40mm]		0.61" [15.5mm]
Antenna Length	0.61" [15.5mm]		1.57" [40mm]
Web/Core Width	2.09" [53.0mm]	1.71" [43.5mm]	1.14" [29.0mm]
Web Pitch	0.88" [22.225mm]		1.88" [47.63mm]
Core ID	6" [152.4mm]*		
Core Material	Fiberboard		
Inlays per Roll	12,500 Nominal (Two Rolls per Box)		7,500 Nominal (Two Rolls per Box)
Maximum Roll OD	< 12" [304.8mm]		
Roll Labeling Data	Roll #, Quantity		

Environmental	
Shelf Life	2 years at +77°F [+25°C] @ 40%RH
Recommended Storage	+77°F [+25°C] @ 40% RH
Storage Limits	-13°F to 122°F [-25°C to +50°C] 20% to 90% RH Non-condensing
Operating Limits	-40°F to +158°F [-40°C to +70°C] 20% to 90% RH Non-condensing
Bend Diameter	> 1.97" [50mm]
Pressure	< 5N/mm ²
Drop Resistance	Per ASTM D5276
Write Cycles	100,000 @ 25°C
RoHs	2002/95/EC, 2005/618/EC, 2011/65/EU Compliant
REACH	1907/2006/EC Compliant (SVHC and ECHA)
ESD Limit- HBM / CDM	5.0kV / 1.5kV

Wet Inlay (WRW)	ALN-9720-WRW
Inlay Width	1.75" [44.45mm]
Inlay Length	0.75" [19.05mm]
Web Width	1.88" [47.65mm]
Web Pitch	0.88" [22.225mm]
Core Width	1.88" [47.65mm]
Core ID	6" [152.4mm]*
Core Material	Fiberboard
Inlays per Roll	12,500 Nominal (Two Rolls per Box)
Maximum Roll OD	< 16" [406.4mm]
Roll Labeling Data	Roll #, Quantity
White	TT Printable White Film Only
Overlay Adhesive	General Purpose Permanent
Inlay Adhesive	General Purpose Permanent
Adhesive Application Temperature	> +25°F [-4°C]
Adhesive Service Temperature	-40°F to +200°F [-40°C to +93.3°C]
Release Liner	40# SCK

RFID	
Protocols Supported	ISO/IEC 18000-6C EPCglobal Class 1 Gen 2
Integrated Circuit	Alien Higgs-4
Operating Frequency	840-960 MHz
EPC Size	128 Bits
User Memory	128 Bits
TID	32 Bits
Unique TID	64 Bits
Access Password	32 Bits
Kill Password	32 Bits

* Shipped with 6" to 3" plastic core adapter
January 21, 2015

Copyright © 2015 Alien Technology LLC. All rights reserved.
Alien, Alien Technology, the Alien Technology logo, Spider, Higgs, Dynamic Authentication, QuickWrite, BlockWrite, Squiggle, and the Squiggle logo are trademarks or registered trademarks of Alien Technology Corporation in the U.S. and other countries.
HANDLING PRECAUTIONS Observe standard handling practices to minimize ESD.
DISCLAIMER Application recommendations are guidelines only - actual results may vary and should be confirmed. This is a general purpose product not designed or intended for any specific application.

This product is covered by one or more of the following U.S. patents: 7967204, 7931063, 7868766, 7737825, 7716208, 7716160, 7688206, 7659822, 7619531, 7615479, 7598867, 7580378, 7576656, 7562083, 7561221, 7559486, 7559131, 7554451, 7551141, 7542201, 7542008, 7531218, 7520055, 7500610, 7489248, 7453705, 7428467, 7417306, 7411503, 7385284, 7377445, 7364084, 7353598, 7342490, 7324061, 7321159, 7301458, 7295114, 7288432, 7265675, 7262686, 7260882, 7253735, 7244326, 7218327, 7214569, 7199527, 7193504, 7173528, 7172910, 7172789, 7141176, 7113250, 7101502, 7080444, 7070851, 7068224, 7046328, 6998644, 6988667, 6985361, 6980184, 6970219, 6952157, 6942155, 6933848, 6927085, 6816380, 6780696, 6731353, 6693384, 6683663, 6665044, 6657289, 6623579, 6606247, 6606079, 6590346, 6586338, 6566744, 6555408, 6527964, 6479395, 6468638, 6420266, 6316278, 6291896, 6281038. Other patents pending.

This product is licensed under patents of Round Rock Research, LLC, for use solely with UHF RFID Readers (such as Alien reader products) that are licensed under an agreement with Round Rock Research, LLC.